

Transmitter-Receiver Light Barrier Type PU2092/2 with 'intelligent' Pollution Warning Output

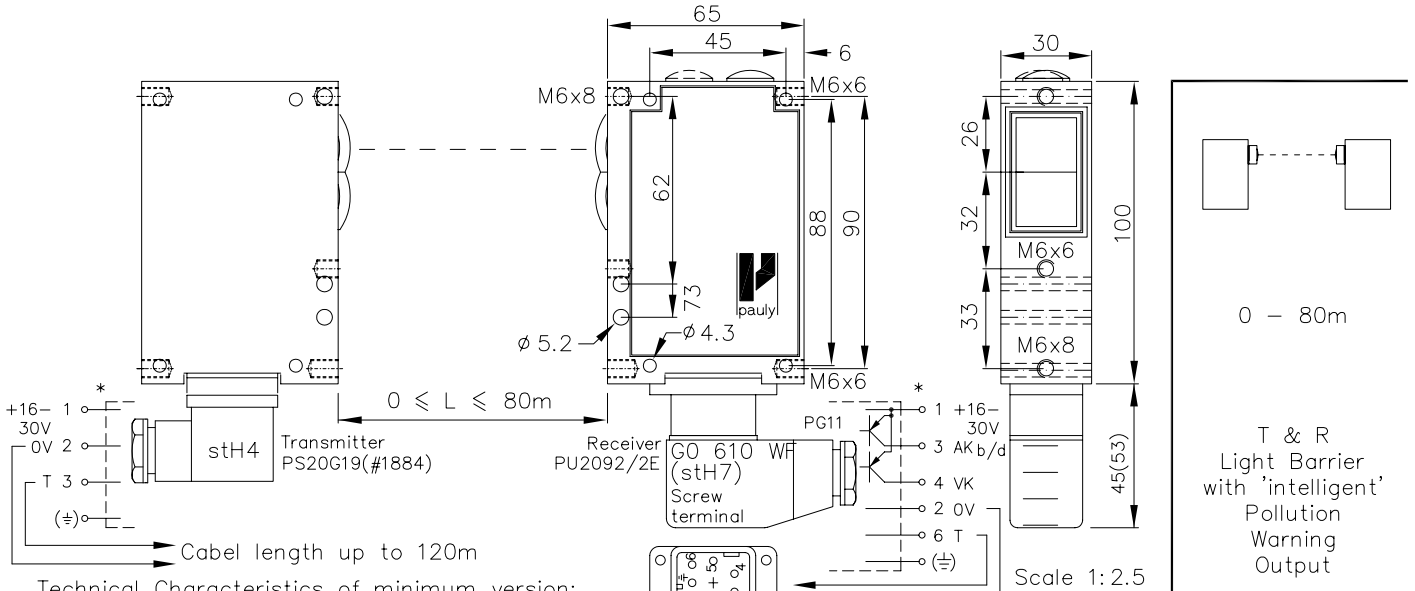

Technical Characteristics of minimum version:

Housing	Al-Cast
Weight	2x approx. 350g
Protection mode	IP65
Connection	Receiver: 6+1 pole Plug stH7 Transmitter: 3+1 pole Plug stH4
Supply	Receiver: 24VDC/40mA without load Transmitter: 24VDC/50mA

Output	pnp 60mA s.c.-prot., e2
Signal mode (AK)	bright/dark selectable
Transmitter light	LED 880 nm, invisible
Steady light resistance	>80kLx
Interference Suppress.	force synchronization
Light beam dia.	approx. 2500mm/20m
Access time	<12ms/switching transition
Switching rate	40/s
Switch indicator	LED's, Receiver
Working indicator	LED's, Transmitter
Ambient temperatur	-30...+80°C (100°C)*

Accessories: *Exceeding the temperature for a short time does not usually impair functioning

- Diafrags
- Optical Filters
- Adjusting flange JF19H (1)
- Elbow tube adjustment JR19(2&3)
- Cooling water flange KW19
- Anti heat shield & anti dust tubes (K)JT19

Hints: The bright-dark switching is standard. This switch is accessible by removing the blanking screw designated 'PG1'. Switching to bright means that the output circuit of the main contact element (here the pnp transistor) is operated when the light emitted from the transmitter reaches the receiver. The switching indicator - LED (green) - for the main contact element always lights up when the light path is free. The turn-on (Ti) and turn-off delay (Ta) for the main contact element is available on request. The delay times are increased by adjusting in a clockwise direction the potentiometer located under the PG2 screw. The adjustable time range lies between approx. 0 and approx. 10 seconds. Alternatively, the following delays are available on request: 1 sec., 3 sec. and 20 sec. The level indicator "DIANA" (Digital ANaloge Anzeige - digital analog indicator) is also optional. DIANA indicates approximately 20-fold to 25-fold levels above the response threshold. It is not necessary for all DIANA LEDs to light up in order for the light barrier to function perfectly! Switching the optional test input to 0V will interrupt the transmitter. The switching equipment for the pollution warning (VK, yellow LED) is switched through when, subsequent to an interruption in light beam (red LED on) and the light path being free again (green LED on), dirt or clogging causes the signal level to be under five times the minimum level (red and green LEDs on) and the light beam is then interrupted again. At this point in time, the light barrier is still fully functional. As soon as the dirt has been removed (green LED on, red LED off), the dirt indicator (yellow LED) switches off. *E_1722.1.TXT*

Bottom view of flange-type socket with pins

*Connection diagram of standard version: 24VDC, e2, stH7

Special Design:

Connection	6+1 pole Plug stA7 6+1 pole Plug stH7 5+1 wire No.-cable K6
Output	nnp 60mA sc-prot., e3
Access time	"q": <2ms/transition
Switching rate	"q": 300/s
Time delay	0-10s, on-off-delay, separately adjustable, Z10
Level indicator	DIANA. i

Heat-protected optical system, pl
If using cooling water flange, then milled wall, y
Testable by turning off transmitter, ta

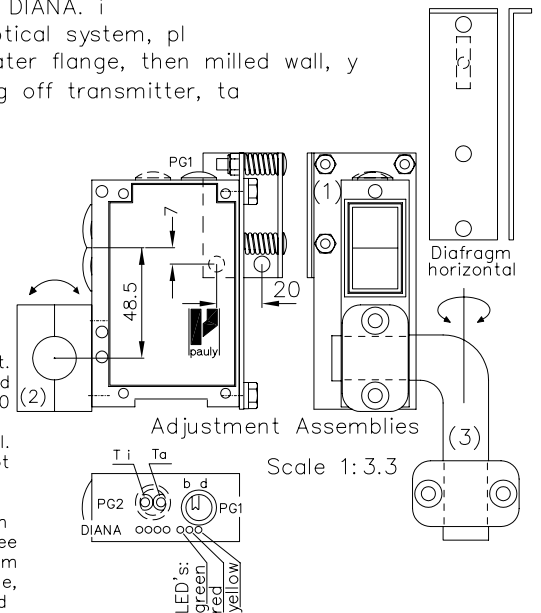

17.02.05 mj
E_1722.1
(24.06.96 tb)
(07.01.03 gs)