

## Transmitter-Receiver Light Barrier Type PV2192 with Pollution Warning Output

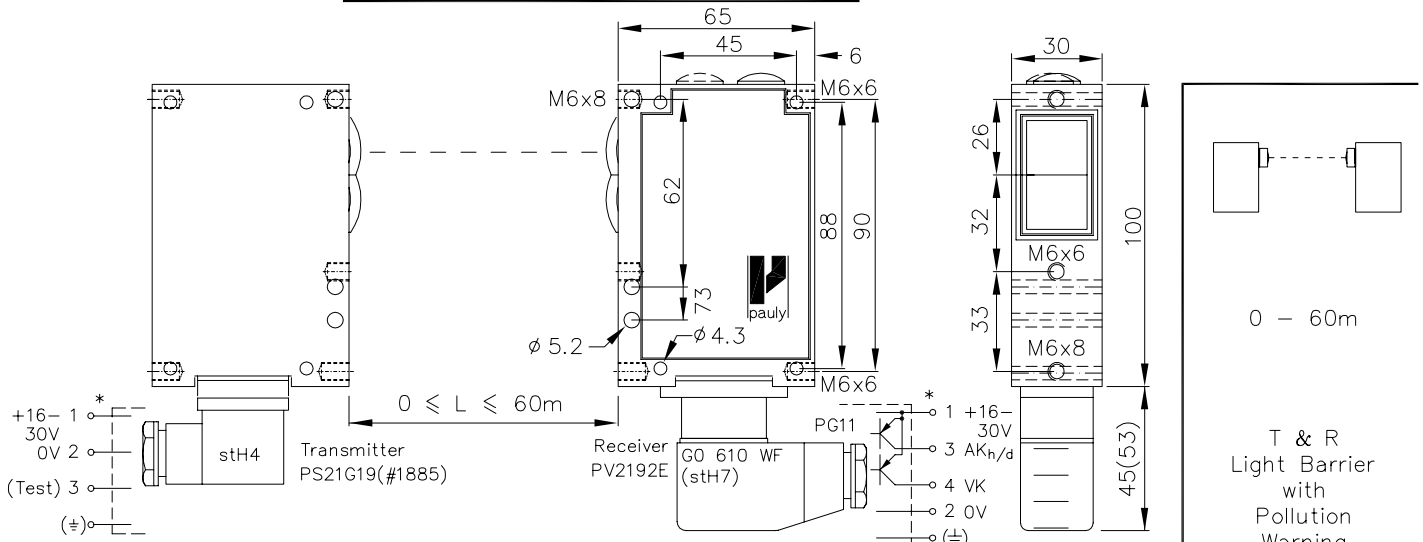

### Technical Characteristics:

Housing	Al-Cast
Weight	2xapprox. 350g
Protection mode	IP65
Connection	Transmitter: 6+1 pole Plug stH7 Receiver: 3+1 pole Plug stH4
Supply	Transmitter: 24VDC/30mA without load Receiver: 24VDC/50mA
Output	pnp 60mA s.c.-prot., e2
Signal mode (AK)	bright/dark selectable
Transmitter light	LED 880 nm, invisible
Steady light resistance	>80kLx
Interference Suppress.	force synchronization
Light beam dia.	approx. 2800mm/50m
Access time	~5ms on; <1ms off
Switching rate	100/s
Switch indicator	LED, Receiver
Working indicator	LED, Transmitter
Ambient temperatur	-30...+80°C (100°C)*

### Special Design:

Connection	4-pole Plug stLU4 4+1 pole Plug stA5 6+1 pole Plug stA7 6+1 pole Plug stH7 4+1 wire No.-cable K5
Supply	different supply on request
Output	nnp 60mA sc-prot., e3
Access time	"d": <2ms/transition
Switching rate	"d": 300/s
Time delay	0-10s, on-off-delay, separately adjustable, Z10
Level indicator	DIANA. i
Heat-protected optical system, pl	
If using cooling water flange, then milled wall, y	
Testable by turning off transmitter, ta	

### Accessories:

Diafragms	
Optical Filters	
Adjusting flange JF19H (1) resp.	
Elbow tube adjustment JR19(2&3)	
Cooling water flange KW19	
Anti heat shield & anti dust tubes (K)JT19	

\*Exceeding the temperature for a short time does not usually impair functioning

**Hints:** The bright-dark switching is standard. This switch is accessible by removing the blanking screw marked PG1. Switching to bright means that the output circuit of the main contact element (here the pnp transistor) is operated when the light emitted from the transmitter reaches the receiver. The switching indicator - LED (green) - for the main contact element always lights up when the light path is free.

The turn-on (Ti) and turn-off delay (Ta) for the main contact element is available on request. The delay times are increased by adjusting in a clockwise direction the potentiometer located under the PG2 screwing. The adjustable time range lies between approx. 0 and approx. 10 seconds. Alternatively, the following time intervals are available on request: 1 sec., 3 sec. and 20 sec.

The level indicator "DIANA" (Digital Analoge Anzeige - digital analog indicator) is also optional. DIANA indicates approximately 20-fold to 25-fold levels above the response threshold. It is not necessary for all DIANA LEDs to light up in order for the light barrier to function perfectly! Connecting the optional available test input to 0V will interrupt the transmitter. The switching equipment for the Pollution Warning (VK, red LED) is switched through when dirt or clogging causes the signal level to be under five times the minimum level.

\*EC 172y 1.TXT\*

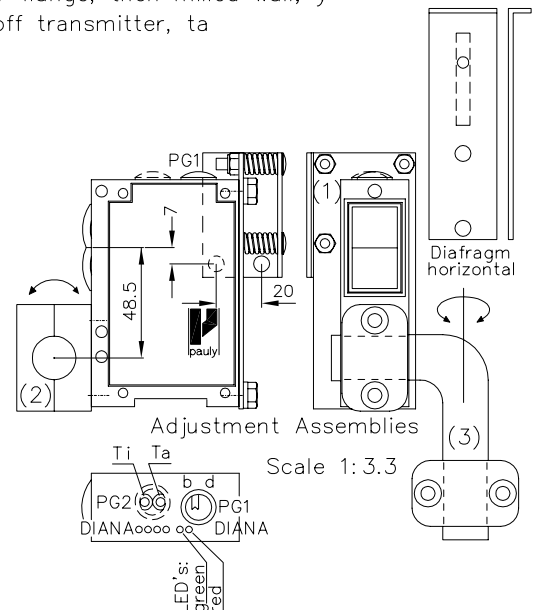

0 - 60m  
T & R  
Light Barrier  
with  
Pollution  
Warning

PV 2192

Order-no.:

1726